

## TECHNICAL BULLETIN

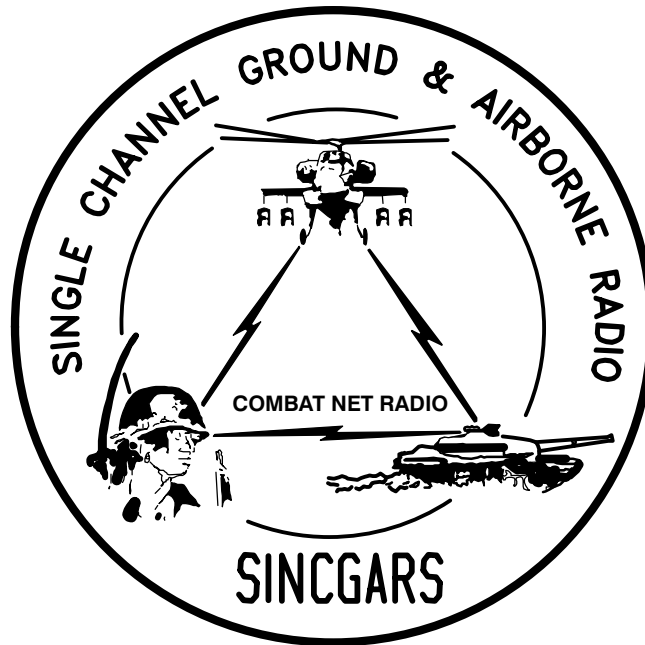

**INSTALLATION INSTRUCTIONS FOR  
INSTALLATION KIT, ELECTRONIC EQUIPMENT  
MK-2204/VRC (NSN 5895-01-225-8658) (EIC: N/A)  
TO PERMIT INSTALLATION OF  
RADIO SET AN/VRC-87/88/90 SERIES  
IN A**

**TRUCK, TANKER, FUEL: 10 TON, 8x8, M978**

**TRUCK, WRECKER: 10 TON, 8x8, M984**

**TRUCK, CARGO: 10 TON, 8x8, M985**

Approved for public release; distribution is unlimited.

---

**HEADQUARTERS, DEPARTMENT OF THE ARMY**

1 AUGUST 1999

**INSTALLATION INSTRUCTIONS FOR  
 INSTALLATION KIT, ELECTRONIC EQUIPMENT  
 MK-2204/VRC (NSN 5895-01-225-8658) (EIC: N/A)  
 TO PERMIT INSTALLATION OF  
 RADIO SET AN/VRC-87/88/90 SERIES  
 IN A  
 TRUCK, TANKER, FUEL: 10 TON, 8x8, M978  
 TRUCK,WRECKER: 10 TON, 8x8, M984  
 TRUCK, CARGO: 10 TON, 8x8, M985**

**REPORTING OF ERRORS AND RECOMMENDING IMPROVEMENTS**

You can help improve this manual. If you find any mistakes, or if you know of a way to improve the procedures, please let us know. Mail your letter, DA Form 2028 (Recommended Changes to Publications and Blank Forms) or DA 2028-2 located in back of this manual direct to: Commander, US Army Communications-Electronics Command Fort Monmouth, ATTN: AMSEL-LC-LEO-D-CS-CFO, Fort Monmouth, New Jersey 07703-5000. The Fax number is 732-532-1413, DSN 992-1413. You may also e-mail your recommendation to AMSEL-LC-LEO-PUBS-CHG@ce-com3.monmouth.army.mil.

In either case a reply will be furnished direct to you.

TABLE OF CONTENTS

Subject	Section	Page
Scope .....	0.1	1
General Information .....	0.2	1
Maintenance Forms, Records, and Reports .....	0.3	1
Reports of Maintenance and Unsatisfactory Equipment .....	0.3.1	1
Report of Packing and Handling Deficiencies .....	0.3.2	1
Discrepancy in Transportation Deficiency Report (TDR) (SF 361) .....	0.3.3	1
Consolidated Index of Army Publications .....	0.4	1
Purpose of Installation .....	1.	2
End Item or System to be Modified .....	2.	2
Application Times .....	3.	2
Time for Completion of Installation .....	3.1	2
Time for Installation of One Assembly or Component .....	3.2	2
Preparation for Installation .....	4.	2
Preparation of Vehicle .....	4.1	2
Preparation of MK .....	4.2	2
MK, Distribution, and Consumables .....	4.3	3
Tools and Test, Measurement, and Diagnostic Equipment (TMDE) Required .....	4.4	7
Installation Procedures .....	5.	8
Installation of Antenna AS-3900/VRC (antenna) .....	5.1	10
Installation of Antenna Base .....	5.1.1	10
Installation of Top Antenna Assembly .....	5.1.2	12
Installation of Mounting Base, Electrical Equipment MT-6352/VRC (mounting base) .....	5.2	13
Installation of Cables .....	5.3	15
Installation of Loudspeaker, Permanent Magnet LS-454/U (speaker) .....	5.4	18
Installation of Loudspeaker, Control-Unit LS-671/VRC .....	5.5	19
Post-Installation and Checkout .....	5.6	20
Appendix A. References .....		A1

\*This manual supersedes TB 11-5820-890-20-11, dated 1 September 1993

LIST OF ILLUSTRATIONS

Figure	Title	Page
4-1	MK Illustrated Parts List . . . . .	5
4-2	Illustrated Parts List for Table 4-2 . . . . .	6
5-1(1)	MK and Radio Installation: MK Equipment Locations . . . . .	8
5-1(2)	MK and Radio Installation: Radio Equipment Locations . . . . .	9
5-3	Top Antenna Assembly Installation . . . . .	12
5-4	Mounting Base Installation . . . . .	13
5-5(1)	Cable Installation: Drilling Grommet Hole . . . . .	15
5-5(2)	Cable Installation: Power and RF Cabling . . . . .	16
5-6(1)	Speaker Installation-A . . . . .	18
5-6(2)	Speaker Installation-B . . . . .	18
5-7	Installation of Loudspeaker, Control-Unit LS-671/VRC . . . . .	19
5-8	Cable Diagram: For AN/VRC-87/88/90 Series . . . . .	21

LIST OF TABLES

Number	Title	Page
4-1	Parts List for Installation of Radio Set AN/VRC-87/88/90 Series . . . . .	4
4-2	Additional Items Required for Installation of "D/F" Radio Sets . . . . .	8

## 0.1 SCOPE

This technical bulletin provides Installation Instructions for Electronic Equipment MK–2204/VRC, commonly referred to as the Mounting Kit (MK). The MK shall be installed into the following type of vehicle(s):

- Truck, Tanker, Fuel:10 Ton, 8x8, M978
- Truck, Tanker, Wrecker:10 Ton, 8x8, M984
- Truck, Tanker, Cargo:10 Ton, 8x8, M985

The MK is used for installation of radio set components at field locations. The information contained in this technical bulletin is the official authorization to perform the installation at the unit maintenance level.

### NOTES

- This technical bulletin is not an authorization for requisition or turn-in of vehicles.
- This technical bulletin does not establish quantity or types of vehicles assigned to using units.

This technical bulletin does not contain information on the maintenance or replacement of the MKs. This information is contained in the MAC of TM 11–5820–890–20–2 and RPSTL of TM 11–5820–890–20P.

## 0.2 GENERAL INFORMATION.

The MK becomes operable when all the radio set components are installed in the vehicle and correct power is supplied. Refer to TM 11–5820–890–20–1 or TM 11–5820–890–20–2 for installation, Operational (OP) Check instructions, and required maintenance procedures. Refer to TM 11–5820–890–20P for repair parts.

Included in the Radio Set AN/VRC–87/88/90 Series is:

- Radio Set AN/VRC–87/88/90 Series (for RT–1523(C)/U)

## 0.3 MAINTENANCE FORMS, RECORDS, AND REPORTS.

**0.3.1 Reports of Maintenance and Unsatisfactory Equipment.** See section 4.2.2.3 for information.

**0.3.2 Report of Packaging and Handling Deficiencies.** See section 4.2.2.1 for information.

**0.3.3 Discrepancy in Transportation Deficiency Report (TDR) (SF361).** See section 4.2.2.2 for information.

## 0.4 CONSOLIDATED INDEX OF ARMY PUBLICATIONS.

Refer to the latest issue of DA Pam 25–30 to determine whether there are new changes, or additional publications pertaining to the equipment.

**1. PURPOSE OF INSTALLATION.**

The Electronic Equipment MK–2204/VRC (MK) contains the items needed to mount Radio Set AN/VRC– 87/88/90 Series in a Truck, Tanker, Fuel: 10 Ton, 8x8, M978; Truck, Wrecker : 10 Ton, 8x8, M984; Truck, Cargo: 10 Ton, 8x8, M985.

**2. END ITEM OR SYSTEM TO BE MODIFIED.**

Not applicable.

**3. APPLICATION TIMES.**

**3.1 Time for Completion of Installation.** Using two people, a total of 2.5 work hours is required. Typical vehicle downtime is 3.0 hours.

**3.2 Time for Installation of One Assembly or Component.** The following table lists the time required to install one component. All times have been rounded off to the nearest half hour. The sum of these times will not reflect the typical vehicle downtime.

ITEM	SECTION	TIME
Antenna, Vehicular AS–3900/VRC	5.1	1.0
Mounting Base, Electrical Equipment MT–6352/VRC	5.2	1.5
Cables	5.3	1.0

**4. PREPARATION FOR INSTALLATION.**

This section explains how to prepare the vehicle and MK for installation.

**4.1 Preparation of Vehicle.** To prepare the vehicle for installation, insure that the site includes adequate lighting and a power source when drilling is required. Inspect the vehicle for damage that could affect installation. Have any such damage repaired before installing MK.

**4.1.1 Items to be Removed.** Remove existing AN/VRC–12 radio family installation kit/harness. See TM 11–5820–401–20–2 for removing items used with intercom systems, or TM 11–5820–401–20–1 (used without intercom systems), and TM 9–2320–279–20.

**4.1.2 List of Items to be Retained.** Not applicable.

**4.2 Preparation of MK.** To prepare MK, unpack, inspect and check inventory.

**4.2.1 Precautions During Handling.** Observe these steps to prevent equipment damage.

- a. Keep dust covers in place on connectors.
- b. Do not disassemble or modify parts in MK unless authorized to do so.
- c. Keep mounting hardware covered and protected until needed.
- d. When exposed to moisture, rain or salt water, keep all parts dry to prevent corrosion.

**4.2.2 Unpack and Inspect Equipment.**

**4.2.2.1 Inspect Packaging for Evidence of Damage.** Any shipping damage should be reported on SF364 Report of Discrepancy (ROD) as prescribed in AR 735–11–2/DLAR 4140.55/NAVMATINST 4355.73A/AFR 400–64/MCO 4430.3F.

**4.2.2.2 Unpack and Inventory MK.** If any item is missing, fill out and forward Transportation Deficiency Report (TDR) (SF361) as described in AR 55–38/NAVSUPINST 4610.33C/AFR 75–18/MCO P4610.19D/DLAR 4500.15.

**4.2.2.3 Examine Each Item for Damage.** If any item is damaged, fill out and forward SF364 Report of Discrepancy (ROD) as prescribed in AR 735–11–2/DLAR 4140.55/NAVMATINST 4355.73A/AFR 400–64/MCO 4430.3F. All damages should be reported as prescribed by DA Pam 738–750, as contained in Maintenance Management Update.

### **4.3 MK, Distribution, and Consumables.**

**4.3.1 Items Supplied in MK and/or Required for Installation.** Use Table 4–1 and figure 4–1 to identify and inventory MK parts supplied to install Radio Set AN/VRC–87/88/90 Series. Refer to Table 4–2 and Figure 4–2 to identify additional items required to install for “D/F” Series Radio Sets.

#### **4.3.2 Distribution and Issue Instructions.**

- a. US Forces: Do not requisition MK. They will be shipped automatically.
- b. US Army Depots: Requisition MK through supply channels.
- c. Multiservice: Instructions shall be included for multiservice modifications.
- d. MAP/MAS Countries: Instructions shall be provided for MAP/MAS countries.

Table 4-1. Parts List for Installation of Radio Set AN/VRC-87/88/90 Series

NSN	ITEM DESCRIPTION AND PART NUMBER	QUANTITY IN MK	SMR CODE	FIGURE, ITEM NO.
5985-01-297-2971	Antenna AS-3900/VRC (A3017899-1)	1	PAOOF A	4-1, 2
5305-00-847-1159	Screw, Cap, Hexagon (3/8-16 x 1 3/4 in) MS35307-365	4	PAOZZA	
5310-00-913-8881	Nut, Hexagon (3/8-16 in) MS51971-3	4	PAOZZA	
5310-00-061-1258	Washer, Lock, Internal/External-Toothed (3/8 in) MS45904-76	8	PAOZZA	
5310-00-889-2527	Washer, Lock, Internal/External-Toothed (5/16 in) MS45904-72 (Not Used)	2	PAOZZA	
5306-00-225-9086	Bolt, Machine (5/16-24 x 5/8 in) MS90726-31 (Not Used)	1	PAOZZA	
5330-01-205-2864	Gasket (A3013655-1)	1	PAOZZA	
5965-00-876-2375	Loudspeaker, Permanent Magnet LS-454/U	1	PAOZZA	4-1, 4
5975-01-188-8873	Mounting Base, Electrical Equipment MT-6352/VRC (A3013367-1)	1	PAOOF A	4-1, 1
5306-00-225-9089	Bolt, Machine (5/16-24 x 1 in) MS90726-34	5	PAOZZA	
5310-00-889-2527	Washer, Lock, Internal/External-Toothed (5/16 in) MS45904-72	10	PAOZZA	
5310-00-880-7746	Nut, Hexagon (5/16 - 24 in) MS51968-5	5	PAOZZA	
5995-01-225-1656	Cable Assembly, Power, Electrical CX-13302/VRC (3 FT, 0 IN) (A3014039-3)	1	PAOZZA	4-1, 7
5995-01-225-1662	Cable Assembly, Radio Frequency CG-3855/VRC (12 FT, 0 IN) (A3014031-12)	1	PAOZZA	4-1, 8
	Bracket, Mounting - Antenna (A3050655-1)	1	XBOZZA	4-1, 5
5340-00-809-1490	Clamp, Loop (1/4 - 1/4 in) MS21333-98	1	PAOZZA	
4020-01-341-8795	Fiber Rope Assembly, Single Leg (A3167672-1)	1	PAOZZA	4-1, 6
5325-01-253-4417	Grommet, Nonmetallic (1/4 in) (A3013068-1)	1	XBOZZA	
5325-00-174-9008	Grommet, Nonmetallic (1/2 in) MS35489-15	1	PAOZZA	
5965-00-043-3463	Handset H-250/U	1	PAOZZA	4-1, 3
5310-00-761-6882	Nut, Hexagon (1/4 -20 in) MS51967-2	4	PAOZZA	
5305-00-225-3839	Screw, Cap, Hexagon (1/4 - 20 x 1 in) MS90725-8	4	PAOZZA	
5975-00-111-3208	Strap, Tiedown, Electrical Components MS3367-5-9	15	PAOZZA	
5310-00-889-2528	Washer, Lock, Internal/External-Toothed (1/4 in) MS45904-68	9	PAOZZA	

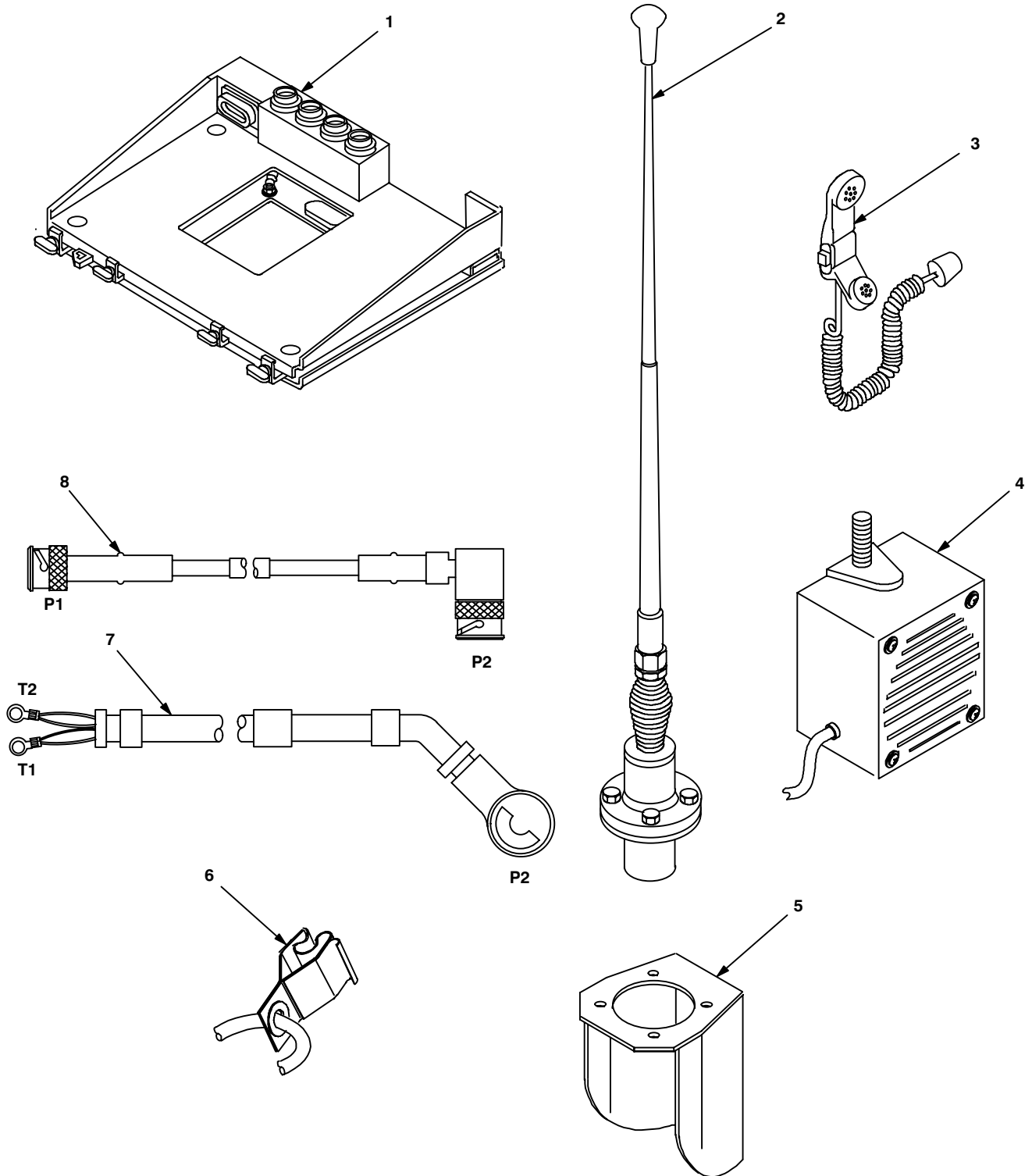
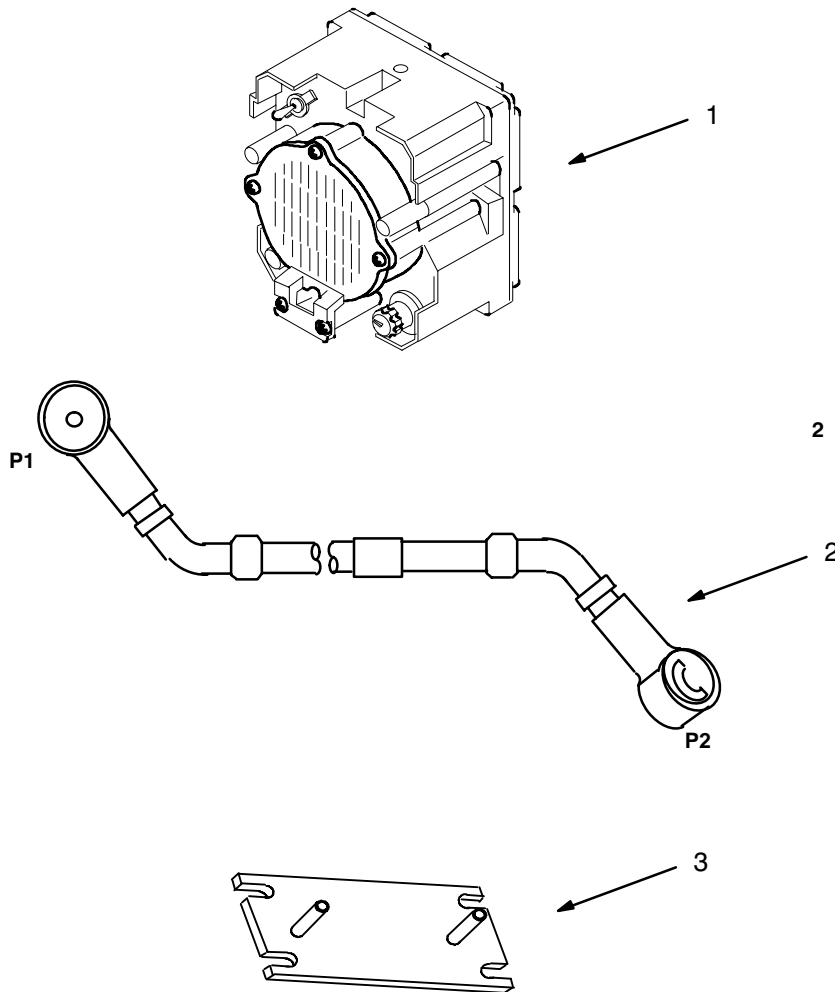

Figure 4-1 (1). MK Illustrated Parts List



**Table 4-2. Additional Items Required for Installation of "D/F" Radio Sets**

NSN	ITEM DESCRIPTION AND PART NUMBER	QUANTITY	SMR CODE	FIGURE, ITEM NO.
5965-01-222-1420	Loudspeaker, Control-Unit LS-671/VRC (A3014065-1)	1	PAOFFA	4-2, 1
5995-01-259-9283	Cable Assembly, Special Purpose, Electrical CX-13292/VRC (8 FT, 0 IN) (A3014038-12)	1	PAOZZA	4-2, 2
	Plate, Mounting (A3014550-1)	1	XBOZZA	4-2,3



**Figure 4-2. Illustrated Parts List for Table 4-2**

**4.3.3 Consumable Materials.** The table below lists materials required for installation but not supplied with MK.

NSN	NOMENCLATURE
8040-00-117-8510	Adhesive-Sealant, Clear, RTV
6850-00-880-7616	Silicone Compound, MIL-S-8660
8030-00-292-1102	Conductive Anti-seize Compound

**4.4 Tools and Test, Measurement, and Diagnostic Equipment (TMDE) Required.** The following tools and TMDE are needed for installation.

NOMENCLATURE	NSN	QUANTITY
Radio Set*		1
Electric Grinder or Equivalent		1
Pocket Knife, Electrician's	5110-00-240-5943	1
Screwdriver, No. 2 Point Phillips, 4 in	5120-00-234-8913	1
Screwdriver, 1/4 in Flatblade, 4 in	5120-00-222-8852	1
Pliers, Round Nose	5120-00-240-6172	1
Pliers, Diagonal Cutting	5110-00-965-0974	1
Wrench, Open/Box: 7/16 in	5120-00-228-9505	1
1/2 in	5120-00-228-9506	1
9/16 in	5120-00-228-9507	1
3/8 in	5120-00-228-9504	1
Handle, Socket Wrench	5120-00-240-5364	1
Socket: 7/16 in	5120-00-227-6703	1
1/2 in	5120-00-237-0977	1
9/16 in	5120-00-227-6704	1
3/8 in	5120-00-227-6702	1
Electric Drill	5130-00-889-8994	1
Drill Bits: 11/32 in	5133-00-227-9664	1
9/32 in	5133-00-222-9374	1
Size 1 (.228 in)	5133-00-189-9246	1
5/8 in		1
5/16 in	5133-00-227-9662	1

\* Use radio issued with your vehicle if available.

### 5. INSTALLATION PROCEDURES.

This section describes where and how to install all MK items in the vehicle. See figure 5-1 for an overall view of where the MK equipment, as well as radio components, will be installed. When installing MK equipment, be sure to read and follow instructions and illustrations carefully.

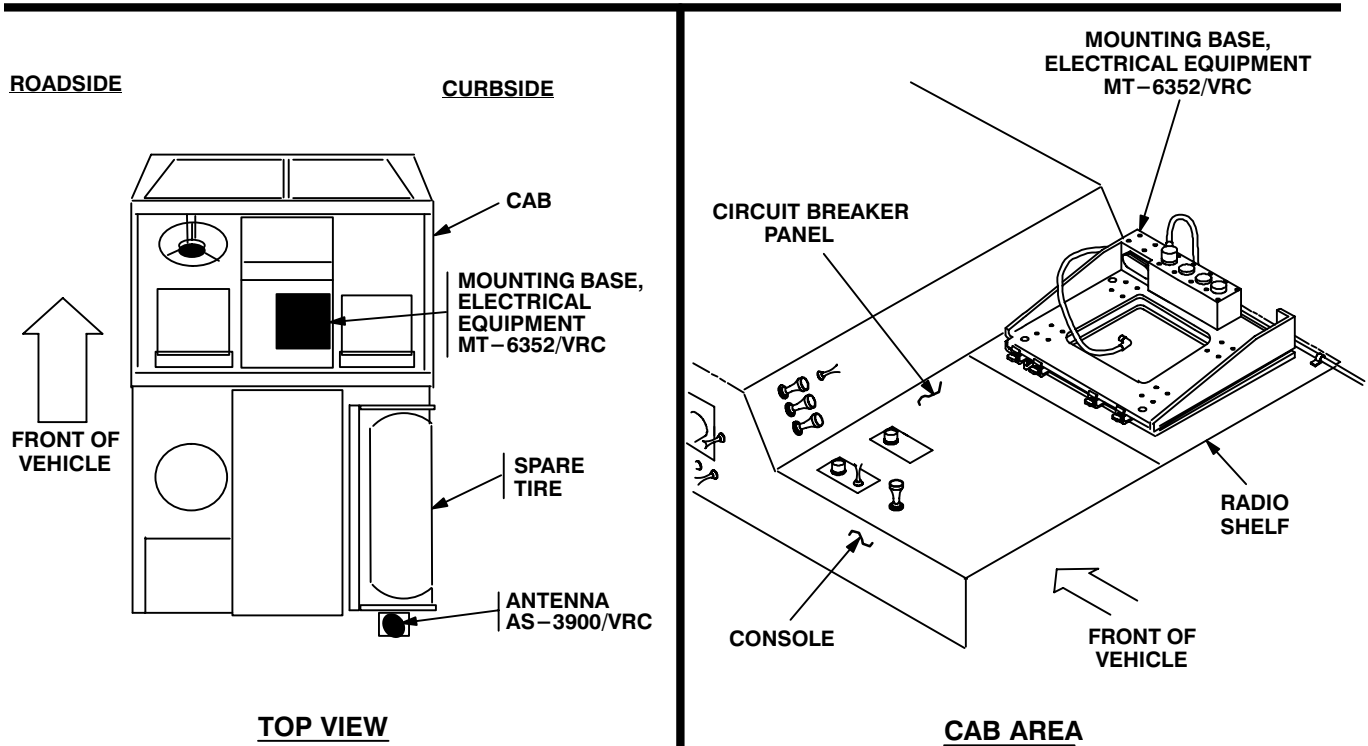
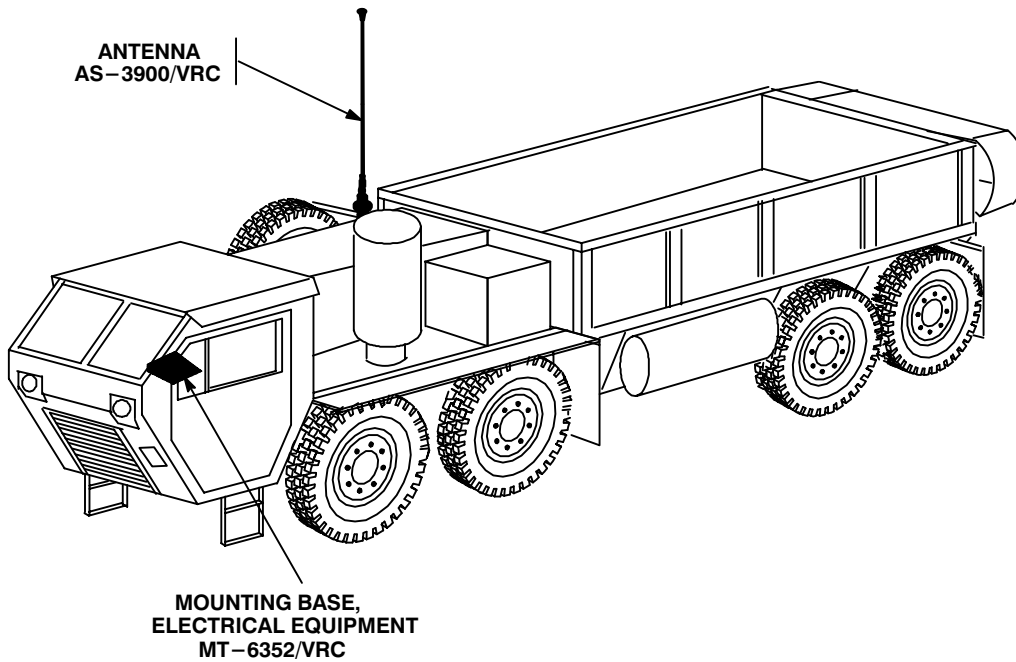

Figure 5-1 (1). MK and Radio Installation: MK Equipment Locations

5. INSTALLATION PROCEDURES. Continued

INSTALLATION  
FOR  
AN/VRC-87/88/90 Series

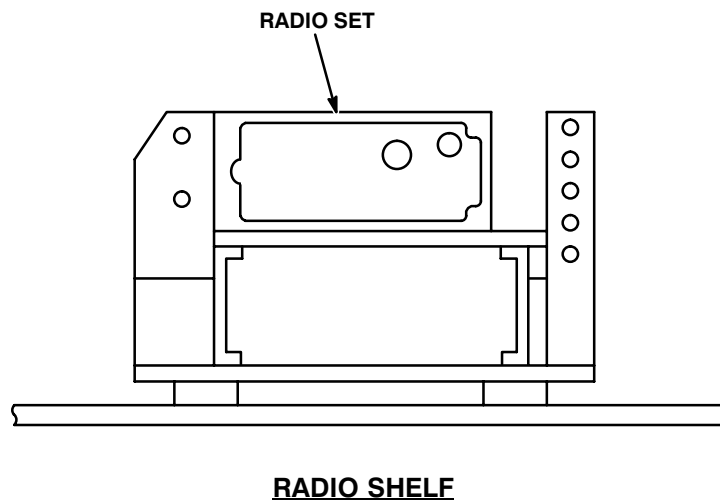

Figure 5-1 (2). MK and Radio Installation: Radio Equipment Locations

5.1 Installation of Antenna AS-3900/VRC (antenna). See figures 5-1 (1) for location.

5.1.1 Installation of Antenna Base.

ITEM	ACTION	REMARKS
------	--------	---------

**NOTE**

Apply a thin coat of adhesive-sealant to both sides of each internal/external-toothed (IET) washer during installation, and to the area of contact where IET washer is to be placed.

- |  |  |  |
|--|--|--|
| a. Antenna bracket (3).  | Place top four holes over existing mounting holes in rear panel behind spare tire. See figure 5-2 (1).   |  |
| b. Three cap screws (4), six internal/external-toothed (IET) washers (2) and three nuts (1). | Install and secure to two upper holes and one lower mounting hole in antenna bracket (3) and rear panel. | Tools: 7/16 in socket and 7/16 in open/box wrench. |

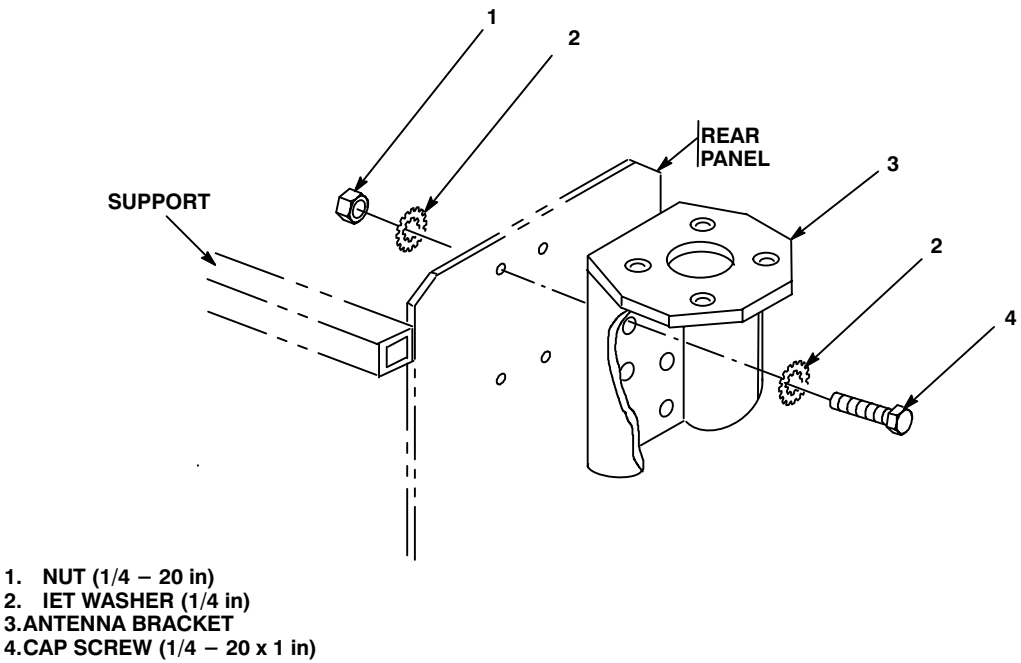
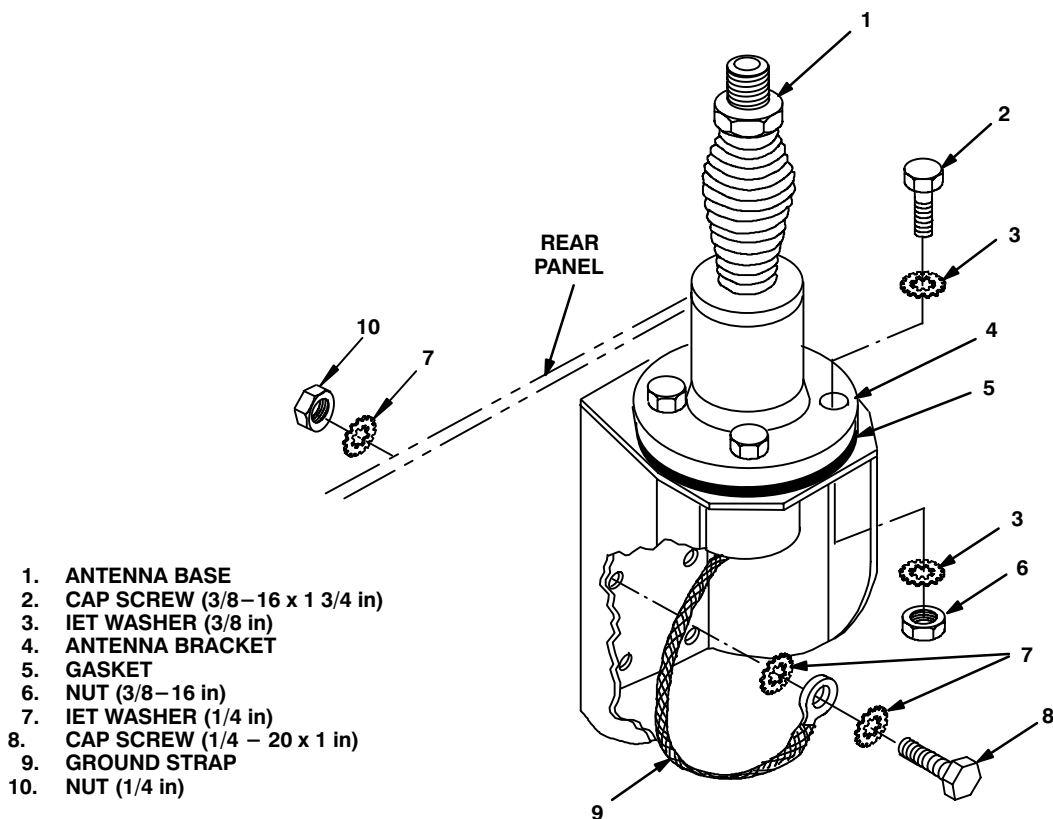

Figure 5-2 (1). Antenna Base Installation: Installing Antenna Bracket

5.1.1 Installation of Antenna Base. Continued

ITEM	ACTION	REMARKS
c. Gasket (5).	Place on antenna bracket (4) and aline mounting holes. See figure 5-2 (2).	
d. Antenna base (1).	Place on top of gasket (5) and antenna bracket (4); then aline mounting holes.	
e. Four cap screws (2), eight IET washers (3) and four nuts (6).	Install and secure to antenna base (1) and antenna bracket (4).	Tools: 9/16 in socket and 9/16 in open/box wrench.
f. Ground strap (9), cap screw (8), three IET washers (7) and nut (10).	Install and secure to lower hole in antenna bracket (4) and rear panel.	Tools: 7/16 in socket and 7/16 in open/box wrench.



- 1. ANTENNA BASE
- 2. CAP SCREW (3/8-16 x 1 3/4 in)
- 3. IET WASHER (3/8 in)
- 4. ANTENNA BRACKET
- 5. GASKET
- 6. NUT (3/8-16 in)
- 7. IET WASHER (1/4 in)
- 8. CAP SCREW (1/4 - 20 x 1 in)
- 9. GROUND STRAP
- 10. NUT (1/4 in)

Figure 5-2 (2). Antenna Base Installation: Installing Antenna Base

**5.1.2 Installation of Top Antenna Assembly.** The top portion of the antenna includes a lower element and an upper element (with installed cap). Use the following procedure to assemble, install and tie down all antennas.

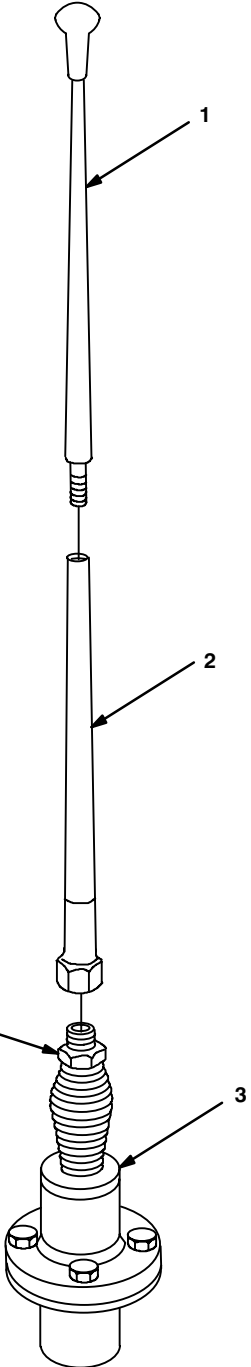
ITEM	ACTION	REMARKS
a. Antenna elements (1, 2).	Apply silicone compound to element threads and assemble. See figure 5-3.	
b. Antenna element (2).	Install and hand-tighten to antenna base (3).	
c. Lock wire (4).	Install to antenna element (2) and antenna base (3). See figure 5-3, detail A.  Cut and remove excess wire with diagonal cutting pliers.	
d. Fiber rope assembly (5).	Attach clip to antenna element (1). Tie rope to vehicle to position antenna in desired location. See figure 5-3, detail B.	

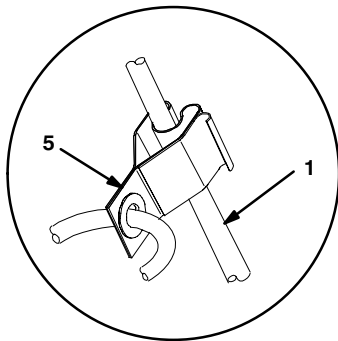

**DETAIL B**

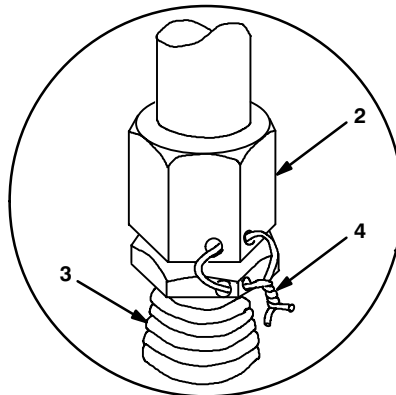

**DETAIL A**

- 1. ANTENNA ELEMENT (UPPER)
- 2. ANTENNA ELEMENT (LOWER)
- 3. ANTENNA BASE
- 4. LOCK WIRE
- 5. FIBER ROPE ASSEMBLY

**Figure 5-3. Top Antenna Assembly Installation**

**5.2 Installation of Mounting Base, Electrical Equipment MT-6352/VRC (mounting base).**

ITEM	ACTION	REMARKS
<b>NOTE</b>		
Apply a thin coat of adhesive-sealant to both sides of each internal/external-toothed (IET) washer during installation, and to the area of contact where IET washer is to be placed.		
a. Existing radio shelf and mounting hardware.	Temporarily remove from console. See figure 5-1 (1) for location.	Tools: Electric drill and 11/32 in drill bit.
b. Mounting base (1).	Remove a 2" square area of paint on the underside of the mounting base (1) around left front and rear mounting holes. Remove a 2" square area of paint on the existing radio shelf around the existing mounting holes that mate with left front and rear mounting holes of mounting base (1). Clean the paint removed areas and apply a thin coat of conductive anti-seize compound.	Tools: Electric grinder or equivalent.
c. Two outer thumbscrews (4).	Turn ccw until both sets of threads have cleared center of holes. See Figure 5-4.	
d. Mounting base (1).	Align four holes and rear slot with matching hole pattern in radio shelf.	
e. Five machine bolts (6), ten IET washers (3) and five nuts (2).	Install and secure to mounting base (1) and radio shelf.	Tools: 1/2 in socket and 1/2 in open/box wrench.
f. Two outer thumbscrews (4).	Tighen and secure to rim clenching clamps (5) and mounting base (1).	
g. Radio shelf.	See section 5.3 for reinstallation.	



**5.2 Installation of Mounting Base, Electrical Equipment MT-6352/VRC (mounting base).** Continued. Remove and retain attaching bag of 5/16 in mounting hardware for installation. To insure good electrical grounding, any rust, corrosion or paint around mounting holes in radio shelf should be removed before installing the mounting base. See figure 5-4 and perform the following steps.

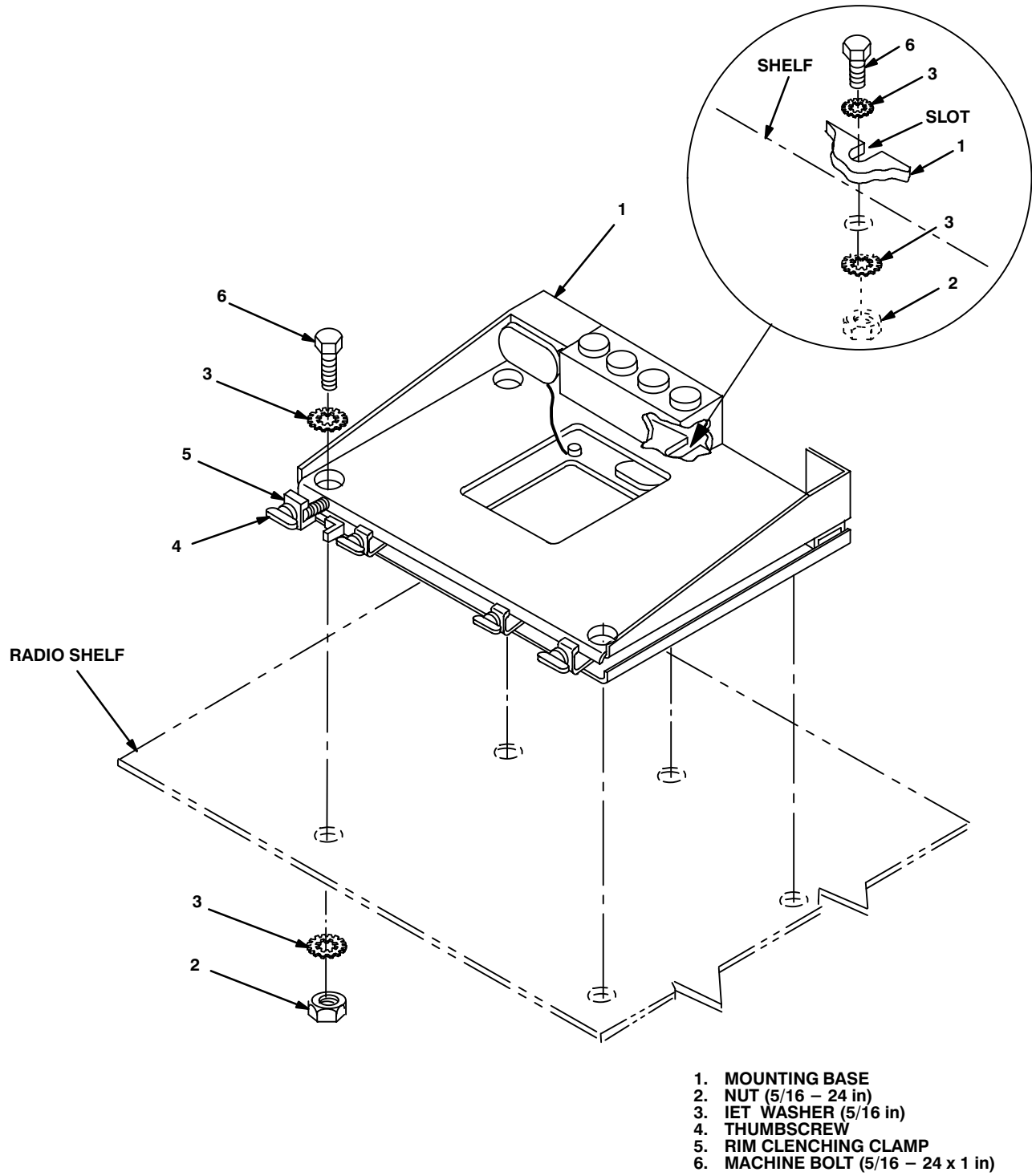

**Figure 5-4. Mounting Base Installation**

**5.3 Installation of Cables.** To accomplish the installation, leave loop clamps and tiedown straps loose enough to adjust cable slack and allow easy adjustment of equipment. When installation is complete, tighten and secure clamps and tiedown straps.

**WARNING**

Make sure vehicle power source is positioned OFF or disconnected before installing cables.

ITEM	ACTION	REMARKS
------	--------	---------

- |   |   |  |
|---|---|--|
| a. Circuit breaker panel and mounting hardware. | Temporarily remove from top of console. See figure 5-5 (1), detail A. |  |
|---|---|--|

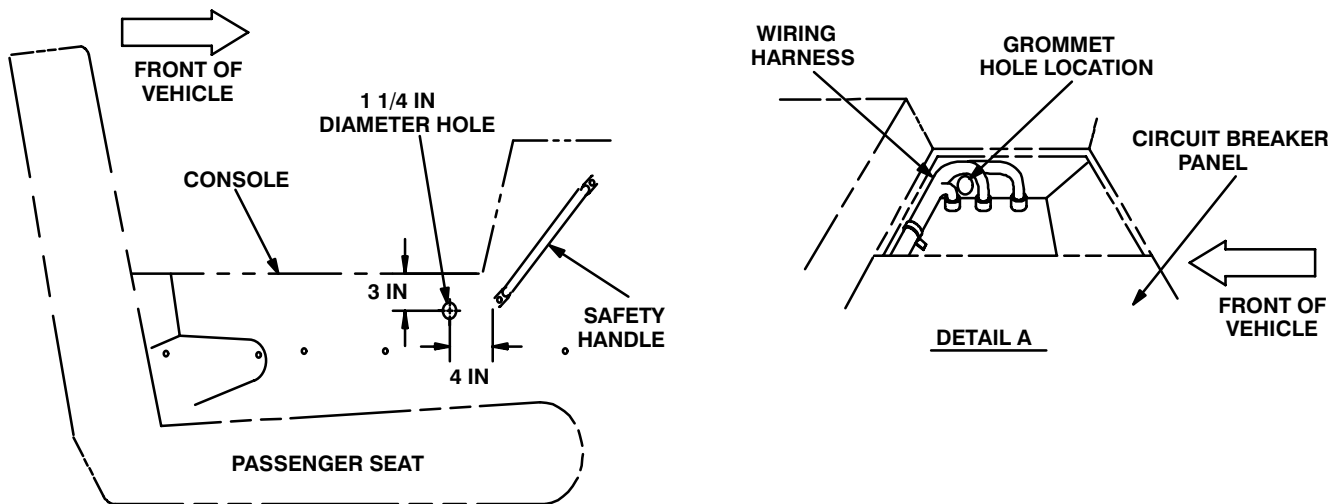

**Figure 5-5 (1). Cable Installation: Drilling Grommet Hole**

**CAUTION**

Be sure to protect existing wiring harness (figure 5-5 (1), detail A) when drilling through side of console.

- |   |  |  |
|---|--|--|
| b. Grommet hole.  | Using the dimensions shown, drill a 1 1/4 in diameter hole through passenger side console. See figure 5-5 (1).         | Tools: Electric drill and 1 1/4 in drill bit.  |
| c. Power cable (1) terminal leads: T1 (red) and T2 (black), figure 5-5 (2). | Insert through hole drilled in step b.   |  |
| d. Grommet (2).   | Cut through on mark shown; then wrap around power cable (1) and install to drilled hole. See figure 5-5 (2), detail A. | Tools: Pocket knife.   |
| e. Power cable (1) terminal leads: T1 (red) and T2 (black).                 | Connect and secure to proper lug on circuit breaker strip. See figure 5-5 (2), detail B.                               | Red (+) secures to No. 4. circuit breaker lug.<br>Black (-) secures to chassis ground. |

5.3 Installation of Cables. Continued

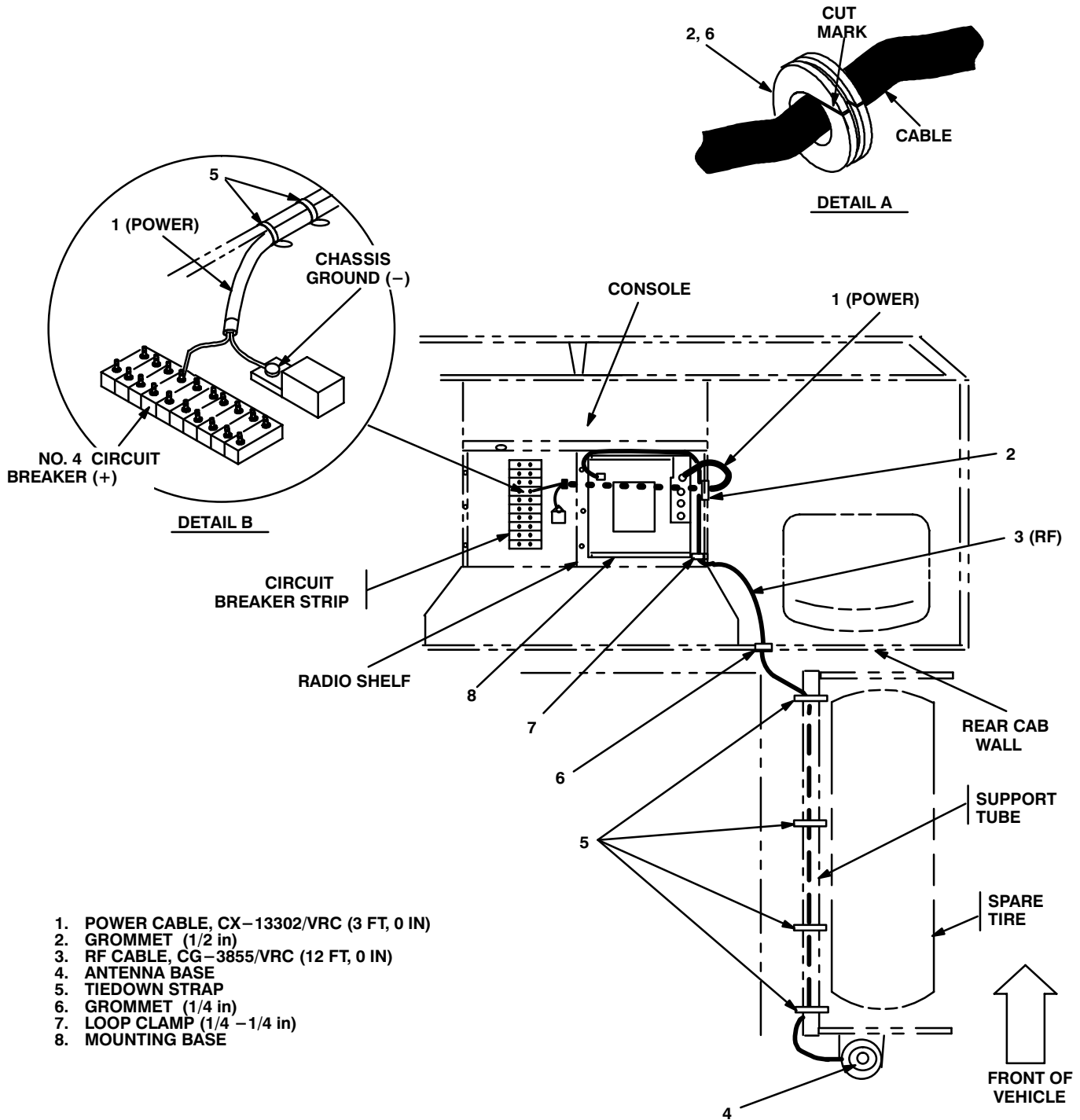

1. POWER CABLE, CX-13302/VRC (3 FT, 0 IN)
2. GROMMET (1/2 in)
3. RF CABLE, CG-3855/VRC (12 FT, 0 IN)
4. ANTENNA BASE
5. TIEDOWN STRAP
6. GROMMET (1/4 in)
7. LOOP CLAMP (1/4 - 1/4 in)
8. MOUNTING BASE

Figure 5-5 (2). Cable Installation: Power and RF Cabling

**5.3 Installation of Cables.** Continued

ITEM	ACTION	REMARKS
<b>CAUTION</b>		
Tie down power cable (1) so that breakout junction (p/o power cable where T1 and T2 terminal leads separate) does not contact circuit breaker strip.		
f. Two tiedown straps (5).	Install loosely around power cable (1), to existing wiring harness. See figure 5–5 (2), detail B for location(s).	
g. Circuit breaker panel and existing mounting hardware.	Reinstall and secure to console. See figure 5–5 (2).	
h. Radio shelf.	Place on console; then reinstall and secure existing mounting hardware, except to mounting hole for loop clamp (7). See figure 5–5 (2) for location.	
i. Power cable (1) connector P2.	Position on top of mounting base (8). See figure 5–5 (2).	
j. RF cable (3) connector P1.	Connect and secure to antenna base (4).	
k. Four tiedown straps (5).	Wrap around RF cable (3), then secure to spare tire support tube. See figure 5–5 (2) for location(s).	
l. RF cable (3) connector P2.	Insert through grommet hole in rear cab wall of vehicle. See figure 5–5 (2).	
m. Grommet (6).	Cut through on mark shown; then wrap around RF cable (3) and install to grommet hole. See figure 5–5 (2), detail A.	Tools: Pocket knife.
n. RF cable (3).	Route behind and along side of mounting base (8). See figure 5–5 (2).	
o. Loop clamp (7) and existing mounting hardware.	Wrap clamp around RF cable (3); then install to existing hole in radio shelf. See figure 5–5 (2) for location(s).	
p. RF cable (3) connector P2.	Position on top of mounting base (8). See figure 5–5 (2).	
q. Sealant.	Apply to and around previously installed grommets (2, 6).	
r. Power cable (1) connector P2.	Connect and secure to mounting base (8) connector J1.	

**5.4 Installation of Loudspeaker LS-454/U (speaker).** Mounting location for speaker may be determined by the vehicle commander. Typical methods used for mounting the speaker are as follows:

**Method A.** See figure 5-6 (1).

- a. Determine speaker (3) location.
- b. Drill 13/32 in diameter hole through mounting surface.
- c. Insert speaker (3) stud through drilled hole; then secure with lock washer (2) and wing nut (1).

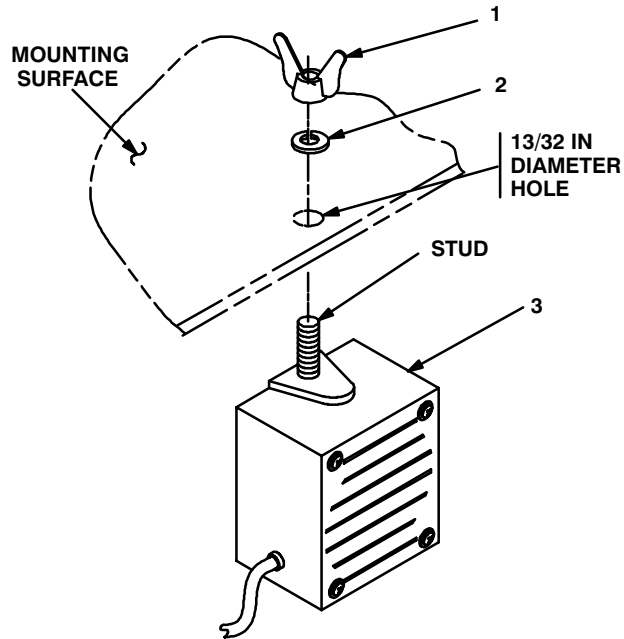

1. WING NUT (3/8-24 in)
2. LOCK WASHER (3/8 in)
3. SPEAKER
4. CAP SCREW (1/4-20 x 1 in)
5. SPEAKER BRACKET
6. LOCK WASHER (1/4 in)
7. NUT (1/4-20 in)

Figure 5-6 (1). Speaker Installation - A

**Method B.** See figure 5-6 (2).

**NOTE**

Items (4), (6) and (7) are not supplied in kit.

- a. Determine speaker (3) location.
- b. Drill two 5/16 in diameter holes through mounting surface.
- c. Install and secure two cap screws (4), two lock washers (6) and two nuts (7) to speaker bracket (5) and mounting surface.
- d. Insert speaker (3) stud through speaker bracket (5) hole; then secure with lock washer (2) and wing nut (1).

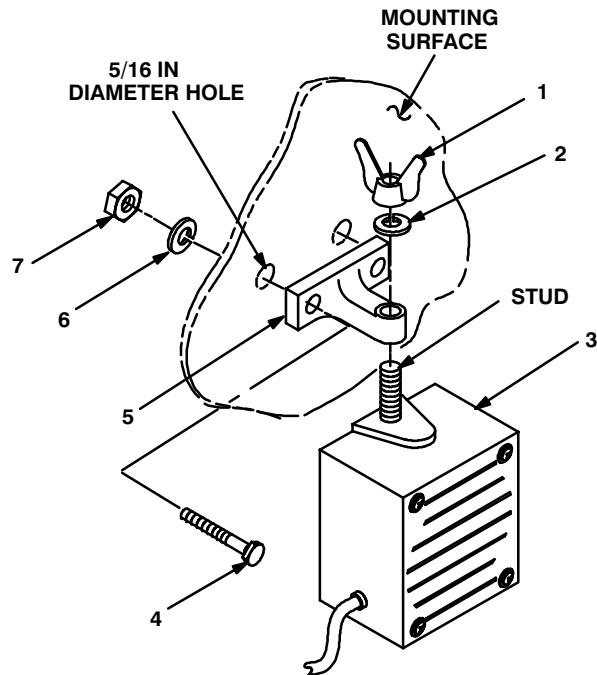
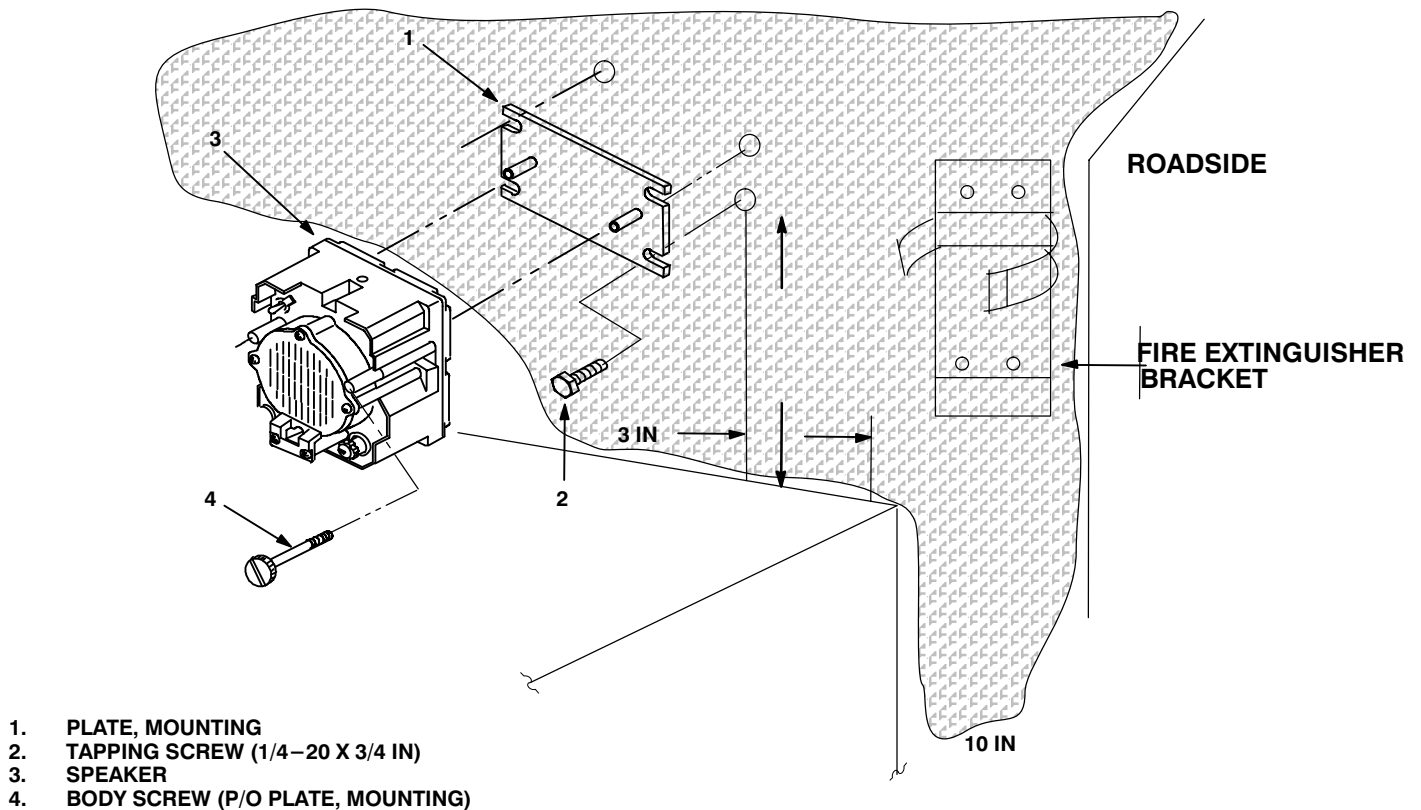

Figure 5-6 (2). Speaker Installation - B

**5.5 Installation of Loudspeaker, Control-Unit, LS-671/VRC (speaker).** Use the following procedures to install the speaker for "D" series radio sets.

ITEM	ACTION	REMARKS
a. Plate, mounting (1).	Use plate, mounting (1) as a template and drill four 7/32 in diameter holes in rear cab wall. See Figure 5-7 for location.	Tools: Electric drill and 7/32 in drill bit.
b. Plate, mounting (1).	Align slots over holes drilled in step a.	
c. Four tapping screws.	Install and secure to plate, mounting (1) and rear cab wall.	Tools: Phillips screwdriver.
d. Speaker (3).	Place on plate mounting (1).	
e. Two externally-relieved body screws (4).	Thread through and secure to speaker (3) and plate, mounting (1).	Tools: Flatblade screw-driver.
f. Handset.	Connect and secure to speaker (3) connector J2.	

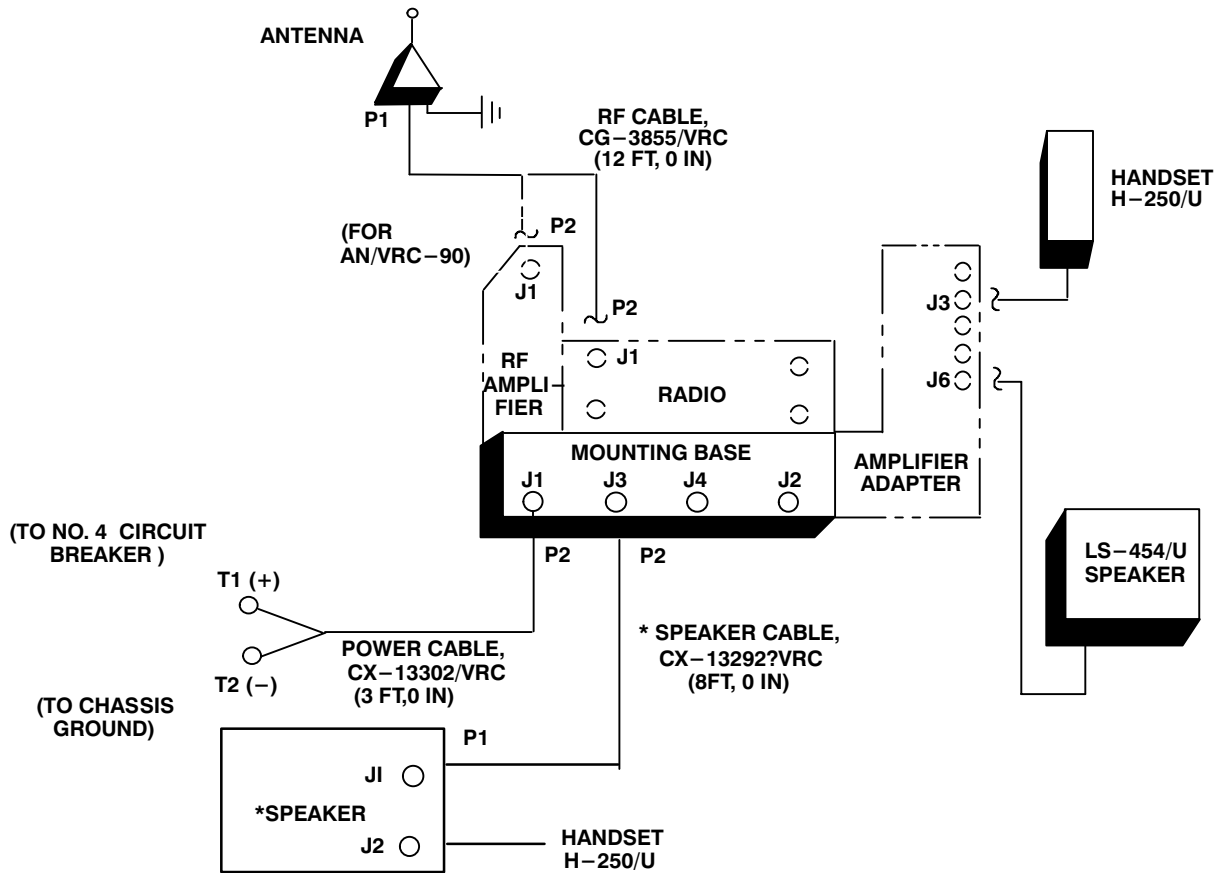

**Figure 5-7. Speaker Installation**

**5.6 Post–Installation and Checkout.** After equipment is installed and cables are connected, perform the following steps.

ITEM	ACTION	REMARKS
a. Equipment.	Check for secure mounting. Check for loose parts, connectors and mounting hardware.	
b. Cables.	Check for proper installation and connection of cables. See figure 5–8 for cable connections. Unused cables should be stowed in appropriate place inside the vehicle.	
c. Loop clamps.	Check that all have been properly installed and tightened.	
d. Protective covers.	Insure that all installed cables are covered when not in use or connected.	
e. Radio issued with vehicle.	Install and connect cables. See TM 11–5820–890–20–1 or TM 11–5820–890–20–2 for installation and Operational (OP) Check instructions.	
f. MK line replaceable units.	See TM 11–5820–890–20P for Repair Parts and Special Tools List (RPSTL) information.	

5.6 Post-Installation and Checkout. Continued



CABLE ASSEMBLY	FROM			TO		
	CABLE CONN.	UNIT	UNIT CONN.	CABLE CONN.	UNIT	UNIT CONN.
CX-13302/VRC (3 FT, 0 IN)	P2	Mounting base	J1	T1: Red (+) T2: Black (-)	No. 4 circuit breaker	Lug (+) Chassis ground (-)
CG-3855/VRC (12 FT, 0 IN)	P1	Antenna base	J1	P2	RF amplifier or radio	J1
Handset cable		Handset			Amplifier-adapter	J3
Speaker cable		LS-454/U speaker			Amplifier-adapter	J6

Figure 5-8. Cable Diagram: For AN/VRC-87/88/90 Series



## APPENDIX A

### REFERENCES

---

AMDF	Army Master Data File (Microfiche)
AR 710-2	Supply Policy Below the Wholesale Level as Contained in Unit Supply UPDATE
AR 725-50	Requisitioning, Receipt and Issuing System in UPDATE
DA Pam 25-30	Consolidated Index of Army Publications (Microfiche)
DA Pam 710-2-1	Using Unit Supply System Manual Procedures as Contained in Unit Supply UPDATE
SB 11-131	Vehicular Radio Sets and Authorized Installations (SINCGARS)
TM 11-5820-890-10-1	Operator's Manual (ICOM Radio Sets)
TM 11-5820-890-10-3	Operator's Manual (Non-ICOM Radio Sets)
TM 11-5820-890-20-1	Unit Maintenance Manual (ICOM Radio Sets)
TM 11-5820-890-20-2	Unit Maintenance Manual (Non-ICOM Radio Sets)
TM 11-5820-890-20P	Repair Parts and Special Tools List

By Order of the Secretary of the Army:

Official:

  
JOEL B. HUDSON  
*Administrative Assistant to the  
Secretary of the Army*  
9920216

ERIC K. SHINSEKI  
*General, United States Army  
Chief of Staff*

DISTRIBUTION:

To be distributed in accordance with the initial distribution number (IDN) 369557 requirements for TB 11-5820-890-20-11.

# SOMETHING WRONG WITH THIS PUBLICATION



THEN ... JOT DOWN THE INFO ABOUT IT ON THIS FORM. CAREFULLY TEAR IT OUT. FOLD IT AND DROP IT IN THE MAIL.

FROM: (PRINT YOUR UNIT'S COMPLETE ADDRESS)

Commander  
Stateside Army Depot  
ATTN: AMSTA-US  
Stateside, NJ 07703-5007

DATE SENT

10 July 1995

PUBLICATION NUMBER

TM 11-5840-340-12

PUBLICATION DATE

23 Jan 74

PUBLICATION TITLE

Radar Set AN/PRC-76

BE EXACT PIN-POINT WHERE IT IS

IN THIS SPACE TELL WHAT IS WRONG AND WHAT SHOULD BE DONE ABOUT IT:

PAGE NO	PARA-GRAPH	FIGURE NO	TABLE NO
2-25	2-28		
3-10	3-3		3-1
5-6	5-8		
		FO-3	

Recommend that the installation antenna alignment procedure be changed throughout to specify a 20 IFF antenna lag rather than 10

REASON: Experience has shown that with only a 10 lag, the antenna servo system is too sensitive to gusting in excess of 25 knots, and has a tendency to rapidly accelerate and decelerate as it hunts, causing strain to the drive train. Hunting is minimized by adjusting the lag to 20 without degradation of operation.

Item 5, Functional column. Change  2 dB" to  3 dB".

REASON: The adjustment procedure for the TRANS POWER FAULT indicator call for a 3 dB (500 watts) adjustment to light the TRANS POWER FAULT indicator.

Add new step f.1 to read,  Replace cover plate removed in step d above."

REASON: To replace the cover plate.

ZONE C 3. On J1-2, change  +24 VDC" to  +5 VDC".

REASON: This is the output line of the 5 VDC power supply. +24 VDC is the input voltage.

PRINTED NAME, GRADE OR TITLE AND TELEPHONE NUMBER

SSG I. M. DeSpirito 999-1779

SIGN HERE

TEAR ALONG DOTTED LINE

# SOMETHING WRONG WITH THIS PUBLICATION



THEN ... JOT DOWN THE INFO ABOUT IT ON THIS FORM. CAREFULLY TEAR IT OUT. FOLD IT AND DROP IT IN THE MAIL.

FROM: (PRINT YOUR UNIT'S COMPLETE ADDRESS)

DATE SENT

PUBLICATION NUMBER

PUBLICATION DATE

PUBLICATION TITLE

BE EXACT PIN-POINT WHERE IT IS

IN THIS SPACE TELL WHAT IS WRONG AND WHAT SHOULD BE DONE ABOUT IT:

PAGE NO	PARA-GRAPH	FIGURE NO	TABLE NO

IN THIS SPACE TELL WHAT IS WRONG AND WHAT SHOULD BE DONE ABOUT IT:

TEAR ALONG DOTTED LINE

PRINTED NAME, GRADE OR TITLE AND TELEPHONE NUMBER

SIGN HERE

FILL IN YOUR  
UNIT'S ADDRESS

FOLD BACK

DEPARTMENT OF THE ARMY



OFFICIAL BUSINESS

PLEASE  
AFFIX  
STAMP  
POSTAGE  
REQUIRED

TEAR ALONG DOTTED LINE

**Commander**  
**U.S. Army Communications-Electronics Command**  
**and Fort Monmouth**  
**ATTN: AMSEL-LC-LEO-D-CS-CFO**  
**Fort Monmouth, New Jersey 07703-5000**



FOLD BACK

